

# Välkommen till Scania Oskarshamn



**SCANIA**





**SCANIA**

# TRATON

G R O U P





# PRODUKTER OCH TJÄNSTER



FJÄRRTRAFIK



ANLÄGGNING



DISTRIBUTION



SPECIALFORDON



STADS- OCH FÖRORTSTRAFIK



LINJE- OCH TURISTTRAFIK



POWER SOLUTIONS



VERKSTÄDER OCH TJÄNSTER



BEGAGNADE FORDON



# SCANIA I VÄRLDEN



# SCANIA EUROPA



**SÖDERTÄLJE**  
SVERIGE



**ZWOLLE**  
NEDERLÄNDERNA



**ANGERS**  
FRANKRIKE



**MEPPEL**  
NEDERLÄNDERNA



**LULEÅ**  
SVERIGE



**LAHTI**  
FINLAND



**SÖDERTÄLJE**  
SVERIGE

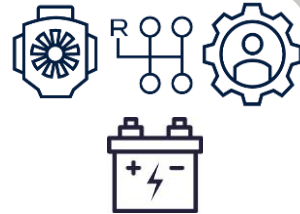

**LAXÅ\***  
SVERIGE



**OSKARSHAMN**  
SVERIGE



**SLUPSK**  
POLEN





# SCANIA OSKARSHAMN

# VÅR HISTORIA

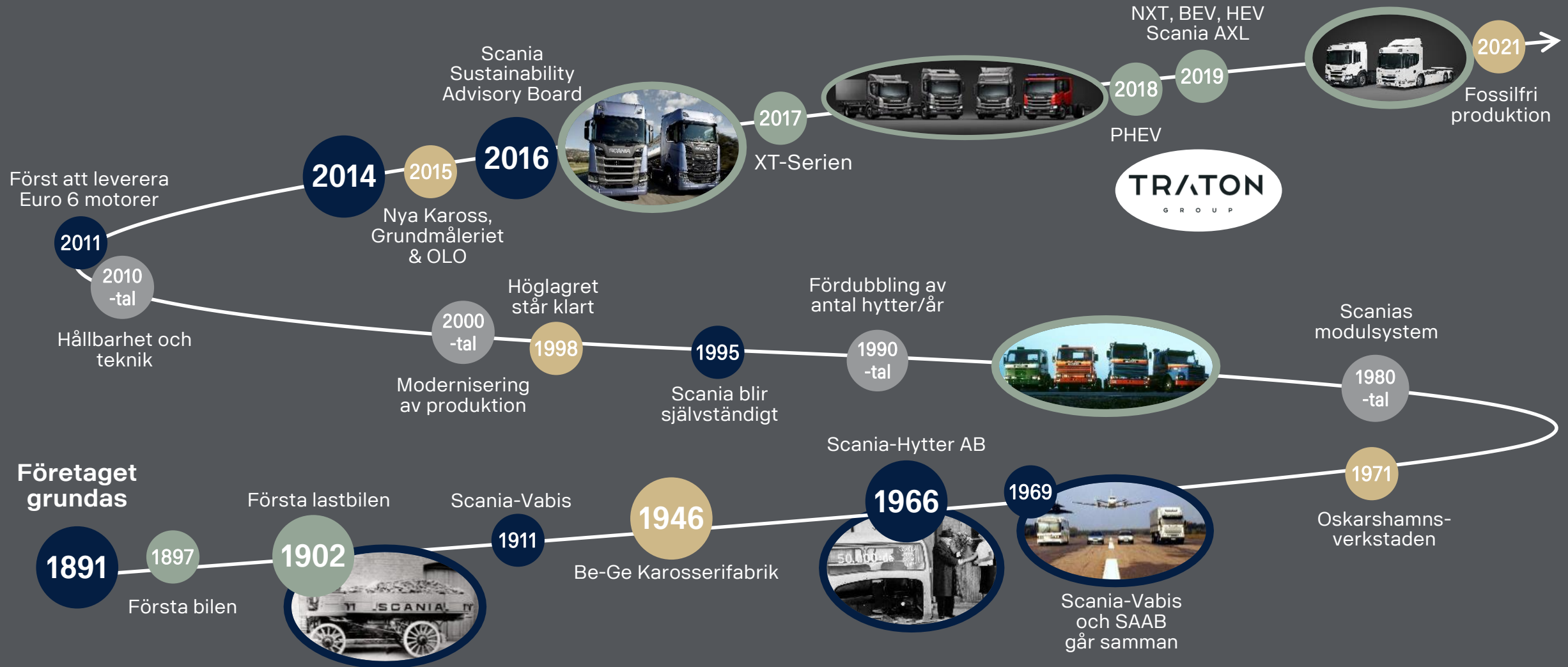

# ORGANISATION OSKARSHAMN

- 2 700 anställda
- Medelålder 40 år
- **Mångfald**  
73% män & 27% kvinnor
- **Fördelning**  
81% verkstadsanställda &  
19% tjänstepersonal



# Alla Hytter till Europa tillverkas i Oskarshamn





# Våra kunder

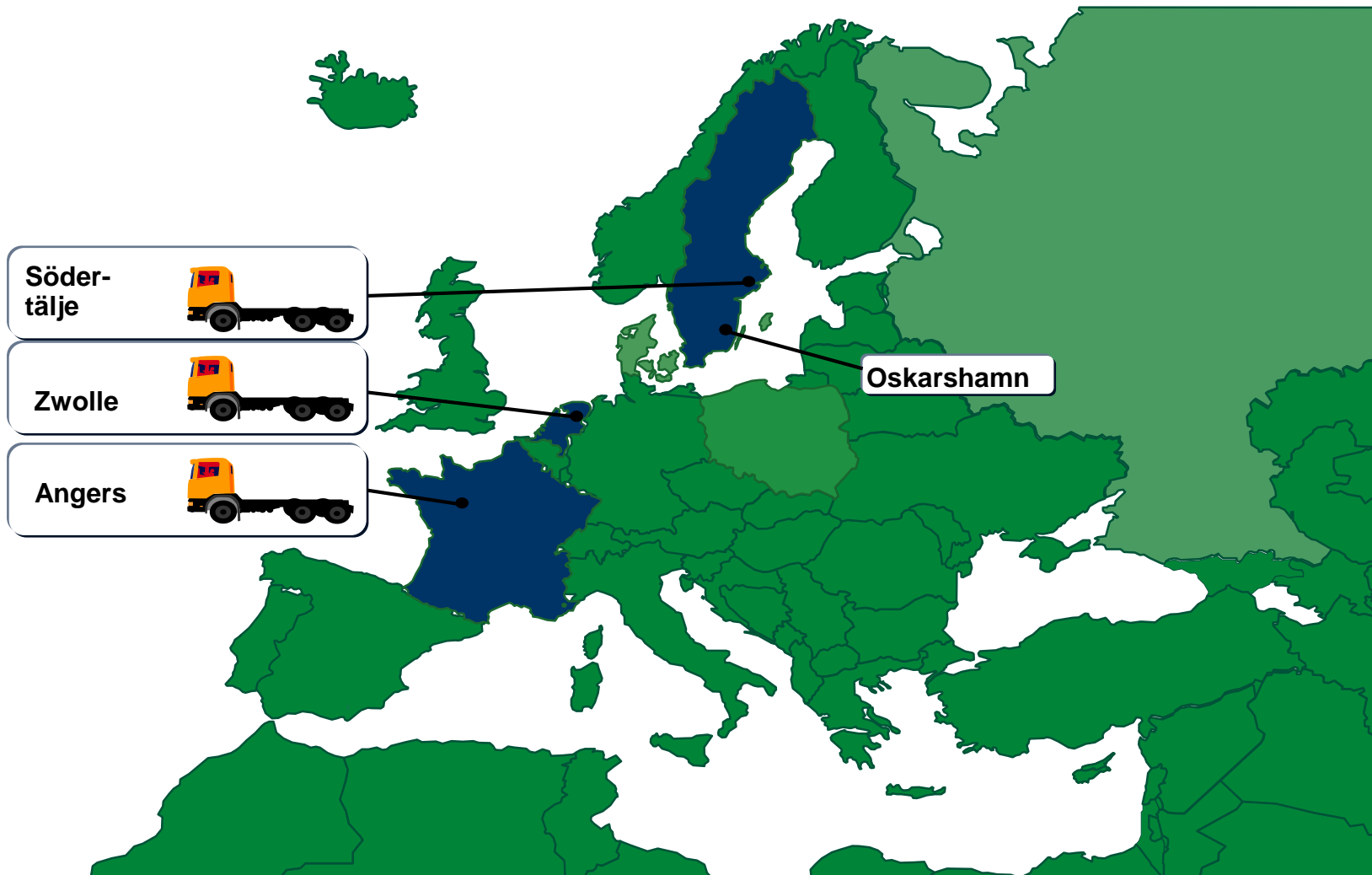



# Modulsystemet

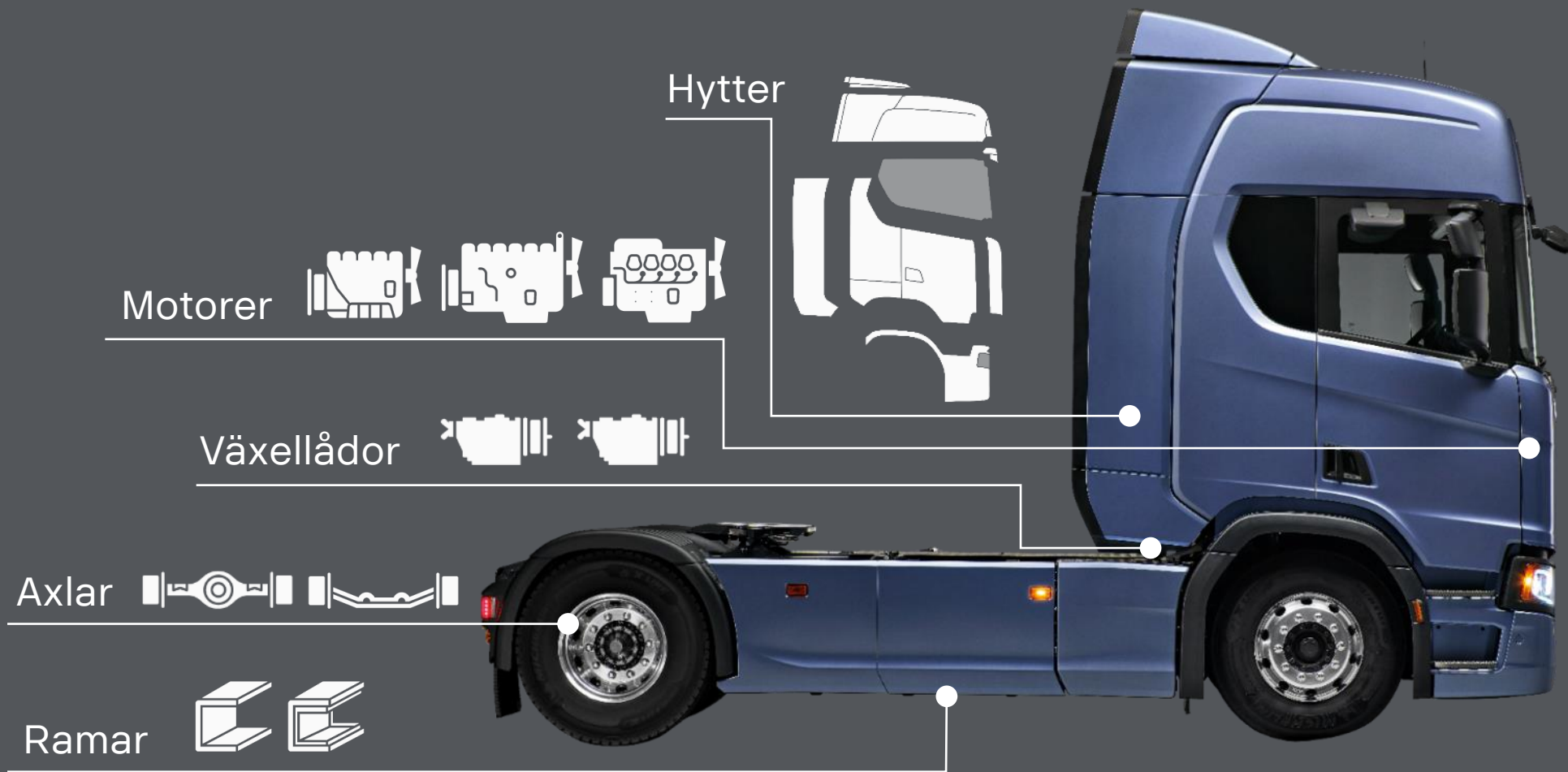

Lastbilar



Bussar



Motorer

# PRODUCTION CONCEPT

## High volume production, Oskarshamn

- 19 cab variants in one single framing line
- Full model flexibility
- Adjustable fixtures for different models
- Simplified fixturing for laser brazing

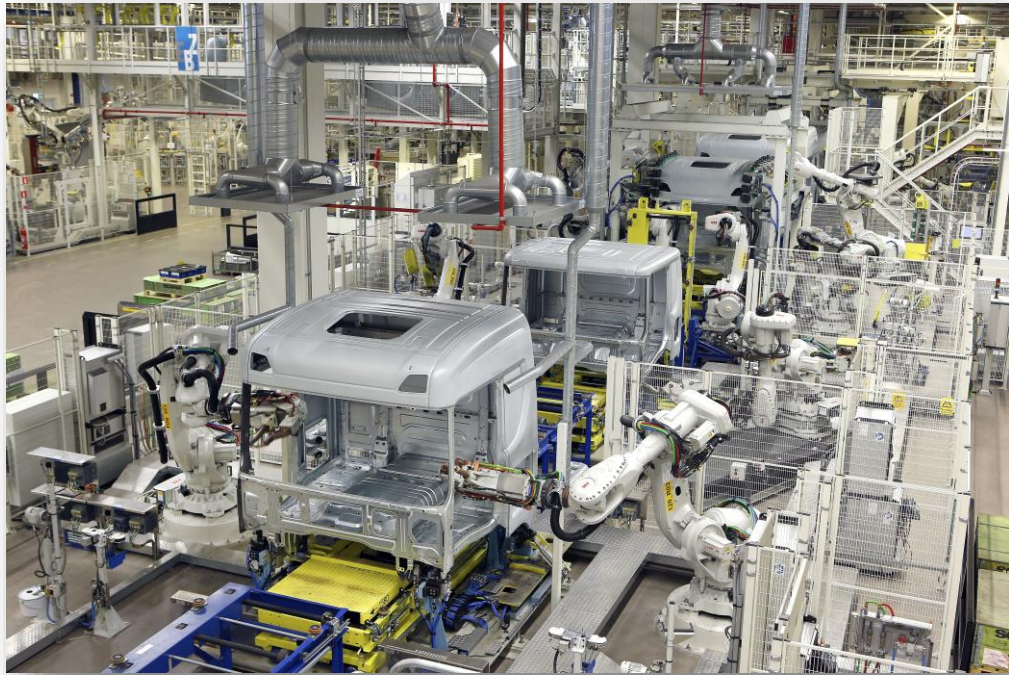

Length	14	17			20			28	31
Roof	Low	Low	Normal	Low	Normal	High	Low	Low	
S									
R									
G									
P									
L									

## Low volume production, Laxå

- 5 cab variants in flexible production line with lower automatization

**SCANIA**

**Primer Paint Shop**



# SCANIA OSKARSHAMN



**Top Coat**



**Press Shop**



**Body Shop**



**Assembly Workshop**



# CAB JOINING TECHNIQUES



## **Welding**

- Spot welding
- Nut welding
- Stud welding
- MAG welding

## **Brazing**

- MIG-brazing
- Laser brazing

## **Adhesive**

- Structural adhesive
- Anti-flutter adhesive
- Hem-flange adhesive





# Punktsvetsning Scania Oskarshamn

- Två typer av elektrodhättor
- B16/6
- B20/8
- A-trode
- (Z-trode)





# Punktsvetsning - HCC

- Heat Capacity Control (HCC)
- Adaptive control
- Expulsion

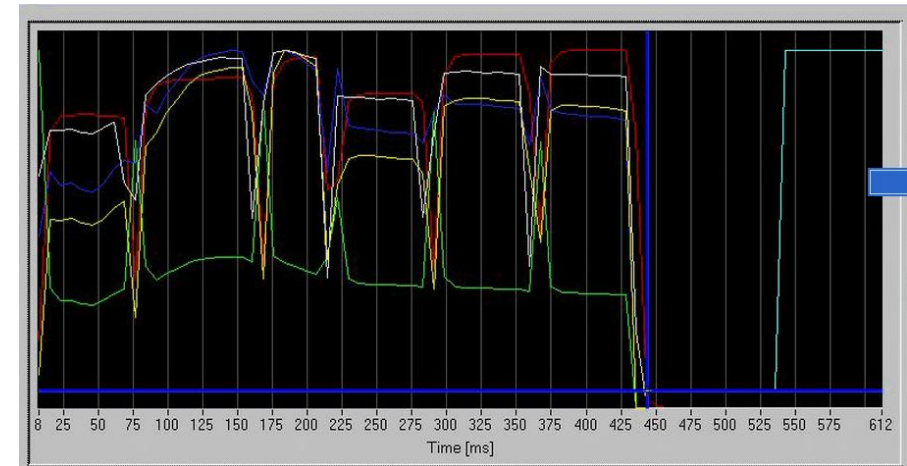
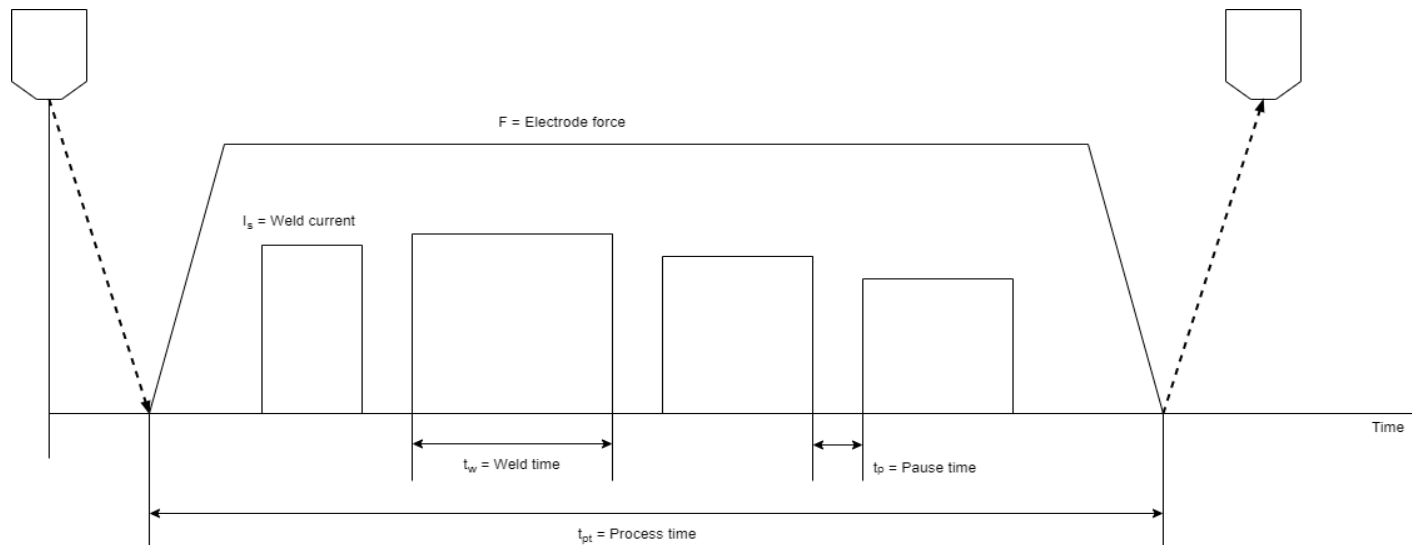



# Lerocon

- Alla muttersvetsmaskiner hos oss är av samma typ (Lerocon 1188)
- Lerocon HMI
- BOS6000
- Svetsmaskin
- Muttermatare
  - Dengensha
  - Swedweld

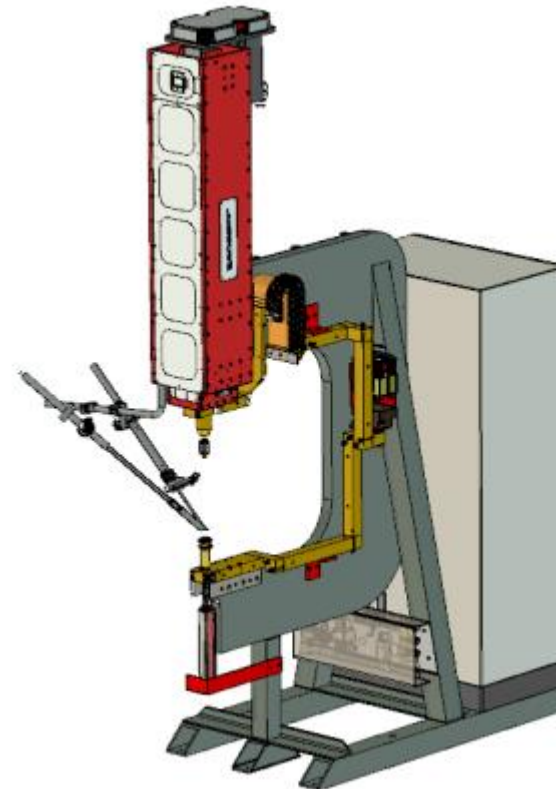



# Muttersvetsning Scania Oskarshamn

- 6st olika mutter typer:
- M6
- M8 square
- M8 flange
- M10 flange
- M12 square
- M16 square

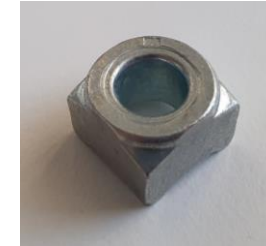



**MED TEAMET  
SOM DRIVKRAFT**

# VÅRA MEDARBETARE ÄR NYCKELN TILL VÅR FRAMTID

Alla anställda på Scania  
bidrar till vårt ständiga  
förbättringsarbete med  
sina erfarenheter, idéer,  
sin kunskap och potential.





# LEDA OMSTÄLLNINGEN

- MOT ETT HÅLLBART TRANSPORTSYSTEM



# HÅLLBARHET PÅ SCANIA

**HÅLLBARA  
TRANSPORTER**  
Att göra rätt saker



Energieffektivitet



Förnybara drivmedel  
och elektrifiering



Smarta och  
säkra transporter

**ANSVARSFULLT  
FÖRETAGANDE**  
Att göra saker rätt



Miljöpåverkan



Jämställdhet,  
inkludering och  
mångfald



Hälsa och  
säkerhet



Mänskliga och  
arbetsrättsliga  
rättigheter



Affärsetik



Samhällspåverkan



# CIRKULÄR PRODUKTION

I Oskarshamn arbetar vi aktivt mot en cirkulär produktion.



**GRÖN EL**



**FOSSILFRI PRODUKTION**



**ÖVERSKOTTSVÄRME**



**DELAKTIGHET**



**PEPPARKAKSPRINCIPEN**



# TILLSAMMANS MOT FRAMTIDEN

AUTOMATION



UPPKOPPLING



ELEKTRIFIERING





# SÄKERHETSREGLER FÖR BESÖKARE



**Rör inte**  
utrustning eller  
komponenter, det kan  
orsaka skador.



**Stäng av**  
**mobiltelefoner**



**Rökning förbjuden**  
Rökning inomhus  
är helt förbjuden.



**Filmning och**  
**fotografering**  
är förbjudet på  
området.

**Håll dig inom** markerade gånglinjer.  
**Lämna företräde** till all trafik och se upp för truckar.  
**Stanna med gruppen** och håll dig alltid nära guiden.  
**Visa respekt** mot våra medarbetare och andra besökare på området.

**SCANIA**



**THANK YOU!**

**SCANIA**



**SCANIA**